



Dear Sir/Madam

As door and hardware professionals we are faced with enormous challenges. Declining margins and demanding customers are but some of the pressures eroding our profitability.

At last there is an affordable software solution, designed for the door and hardware industry that is guaranteed to improve your firm's sales and administrative productivity. The Door Boss system automates the entire sales cycle.

- Quotations
- Shop drawings/hardware schedules.
- Purchasing.
- Change order management.
- Shipping bills.
- Invoices.
- Division 10

As a demonstration of the power of this system I have attached the documents for a fictitious project that I entered into the system in **19 minutes.**

I invite you to sign up for live demo of the system at [www.doorboss.com](http://www.doorboss.com)

Yours Truly

Gerry Muller  
[gerry@doorboss.com](mailto:gerry@doorboss.com)  
(226) 444-1060

TAKE OFF

AL SCHMIDT

MYLES REENTRY OFFICE EXPANSION,  
 CLOSING NOV. 8 12:00.

ARCH #	# Closer	FROM #	TO	SIZE	DOOR TYPE	DOOR MAT	RTG	FR ELEV	FR MAT	JAMB DEPTH	NOTES
1	RHL	CARR	EXT.	3°X7°	F	1960 INV	/	A	166A 7/B	8 3/4	
2	RH	CARR	AFFICE #1	3°X7°	F	5C OAK	/	542	15-16	5 3/4	
3	LH	"	AFFICE #2	"	"	"	/	"	"	"	
4	LH	"	"	"	F	"	/	"	"	"	
5	RH.	"	w/R	"	"	"	/	A	19W-19	5 3/4	
6	LH	"	"	"	"	"	/	"	"	"	
7	RH.	"	MECH ROOM	"	F	206A	/	"	"	"	
8	LH	"	BOARD ROOM	2-3°X7°	F6.	5C OAK	/	"	"	"	
9	LH	"	LUNCHRN	3°X7°	G	"	/	"	"	"	

ADD. #



# Muller Hardware and Supply Corp.

9-665 Industrial Rd., Cambridge ON, N3H 5C9 Tel 226-444-1060 Fax 610-271-5192

## Contract quotation - job #29

Date: Nov 09,2010  
Customer: Sunshine Contracting.  
Project: Melburn ROI Inc. office addition  
Prepared by: Gerry Muller

Attn: James

### Hollow Metal

1 Door(s)

Supply only .....	\$ 285.06
County tax	\$ 11.40
<b>Total</b>	<b>\$ 296.46</b>

**Note:** Based on 18 Ga. doors, 18 ga KD frames and 16 ga. welded screens.

### Wood

12 Door(s)

Supply only .....	\$ 2,941.50
County tax	\$ 117.66
<b>Total</b>	<b>\$ 3,059.16</b>

**Note:** Based on 5 ply oak doors with oak edges. All doors factory machined for hardware.

### Finish Hardware

- 1 Continuous hinge \* SL-11 83" \* AL
- 1 Closer \* 4140 H-Cush \* 689
- 4 Push Plate \* CDH93A 5 x 20 \* C32D
- 4 Closer \* 1460 \* 689
- 1 Sweep \* W13S/36 \* AL
- 1 Lock Set \* AL80PD SAT 10=025 \* 626
- 6 Lock Set \* AL53PD SAT 10-025 \* 626
- 5 Kick Plate \* CDH92A 8 x 34.5 \* C32D
- 4 Pull \* CDH5109-1 \* C32D
- 1 Threshold \* CT10/36 \* AL
- 13 Floor Stop \* CDH212 \* C26D
- 36 Hinge \* BB1279 4.5 x 4 \* C26D
- 2 Latchset \* AL10S SAT 10-025 \* 626
- 1 Weatherstrip \* W2/17 \* AL

Supply only .....	\$ 3,607.98
County tax	\$ 144.32
<b>Total</b>	<b>\$ 3,752.30</b>

**Total price**

Supply only .....	\$ 6,834.54
County tax	\$ 273.38
<b>Total</b>	<b>\$ 7,107.92</b>

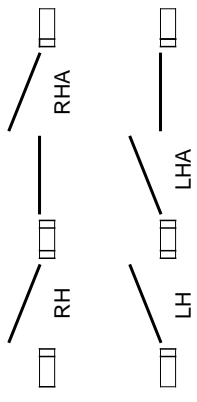
<p><b>General Notes</b></p> <p>Fabrication of materials shown will commence upon approval by the architect and receipt of approved hardware list.</p> <p>Doors and frames will be reinforced for surface mounted hardware as required. Drilling and tapping for surface hardware is by others. Doors and frames will be prepared and reinforced for mortised hardware. All holes will be tapped and drilled except for trim mounting holes.</p> <p>Doors and frames will be manufactured of zinc-coated steel touched up with zinc-rich primer, where zinc coating has been removed due to welding.</p> <p>Frames will be prepared for rubber bumpers.</p> <p>Note! General Contractor is responsible for frames and doors set plumb, square and level.</p>	<p><b>Miscellaneous Notes</b></p> <p>* Please verify swing at door #101</p> <p>* All oak doors to be 5 ply oak with oak edges c/w factory machining.</p>	<p><b>Abbreviations</b></p> <p>Dr.= door Fr.= frame Anch.= anchor Ga.= gauge Hcomb.= honeycomb core Poly.= polystyrene core Wd.= wood (door) Hm.= hollow metal Ps.= pressed steel De.= double egress RH.= right hand LH = left hand RHR.= right hand reverse LHR.= left hand reverse Pr.= pair RHA.= right hand active LHA.= left hand active GPW.= Georgian polished wire (glass) D/I = dead lock 161 = govt. 161 lock prep. 86 = mortise lock prep. FB = flush bolt prep. s/bolt = surface bolt Reinf. = reinforcing S = reinf. for standard mount closer. PA = reinf. for parallel arm closer. TJ = reinf. for top j</p>
	<p><b>Muller Hardware and Supply Corp.</b> 9-665 Industrial Rd., Cambridge ON, N3H 5C9 Tel 226-444-1060 Fax 610-271-5192</p> <p style="text-align: center;"><b>Shop drawing</b></p>	<p>Project: Melburn ROI Inc. office addition Architect: ABC Design Inc. General Contractor: Sunshine Contracting. Date prepared: Nov 09,2010</p>
		<p style="text-align: center;"><b>Swing diagram</b></p> 
		<p style="text-align: right;">Sheet 1 of 6</p>

Op#	Arch#	Location	FRAMES						DOORS						Notes		
			Size	Elev	Series	Matl	Depth	Head	FR	Ancrs	Size	Elev	Series	Matl		Hand	Core
101	101	existing building to corridor 101	40X86	A	AS16	HM	5 3/4	2	.75 hr	Strap anchor	36X84X1 3/4	2G	LS18	HM	LHR	HComb	undersize door 3/16 for SL-11 continuous hinge
102	102	corridor 101 to office 102	60X86	C(L)	AS16	HM	5 3/4	2		Drywall Clips	36X84X1 3/4	F	A25	oak	LH	Particle	
103	103	Corridor 101 to office 103	60X86	C(L)	AS16	HM	5 3/4	2		Drywall Clips	36X84X1 3/4	F	A25	oak	RH	Particle	
104	104	Corridor 101 to office 104	60X86	C(L)	AS16	HM	5 3/4	2		Drywall Clips	36X84X1 3/4	F	A25	oak	LH	Particle	
105	105	Corridor 101 to office 105	60X86	C(L)	AS16	HM	5 3/4	2		Drywall Clips	36X84X1 3/4	F	A25	oak	RH	Particle	
106	106	Corridor 101 to office 106	60X86	C(L)	AS16	HM	5 3/4	2		Drywall Clips	36X84X1 3/4	F	A25	oak	LH	Particle	
107	107	Corridor 101 to office 107	60X86	C(L)	AS16	HM	5 3/4	2		Drywall Clips	36X84X1 3/4	F	A25	oak	RH	Particle	
109	109	Corridor 108 to lunch room 108	40X86	A	DW18	HM	5 5/8	2			36X84X1 3/4	G	A25	oak	LH	Particle	
110	110	corridor 108 to mens restroom 110	40X86	A	DW18	HM	5 5/8	2			36X84X1 3/4	F	A25	oak	LH	Particle	
111	111	corridor 108 to womens restroom 111	40X86	A	DW18	HM	5 5/8	2			36X84X1 3/4	F	A25	oak	RH	Particle	
112	112	Corridor 108 to storage 112	36X86	A	DW18	HM	5 5/8	2	.75 hr		32X84X1 3/4	F	A25	oak	LH	Particle	
113	113	Corridor 108 to boardroom 113	96X86	D(R) DBL	AS16	HM	5 3/4	2		Drywall Clips	36X84X1 3/4	FG	A25	oak	LHA/RH	Particle	
114	114	Corridor 108 to exterior	40X110	TRA	AS16	HM	8 3/4	2		Wire Masonry	36X84X1 3/4	NL	LS18	HM	RHR	PolyS	

### Muller Hardware and Supply Corp.

9-665 Industrial Rd., Cambridge ON, N3H 5C9  
Tel 226-444-1060 Fax 610-271-5192

Project: Melburn ROI Inc. office addition  
Architect: ABC Design Inc.  
General Contractor: Sunshine Contracting.  
Date prepared: Nov 09,2010

## Shop drawing



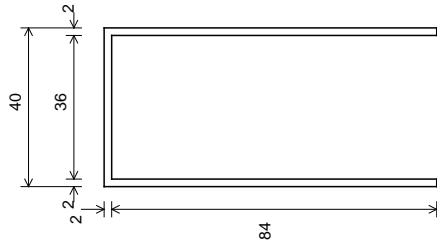

**Elev A**

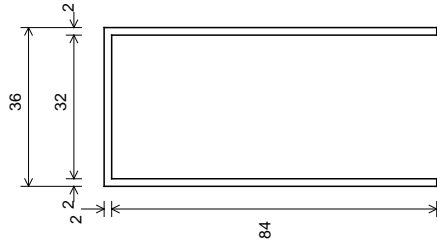

**Elev A**

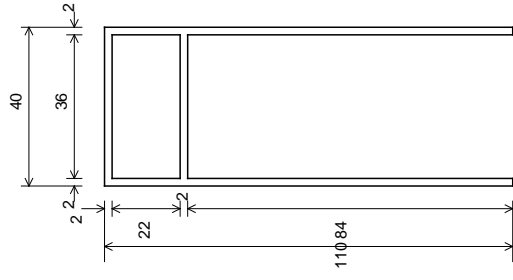

**Elev TRA**

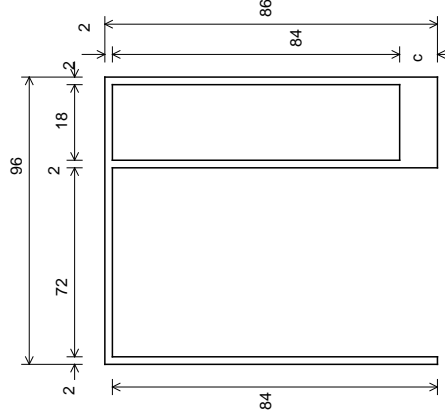

**Elev D (R) DBL**

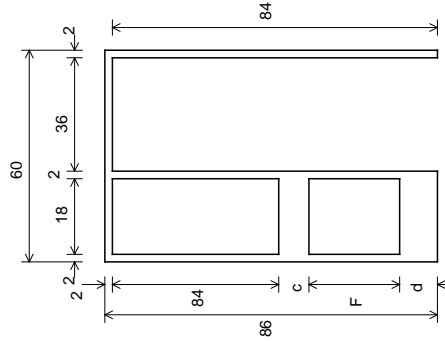

**Elev C (L)**

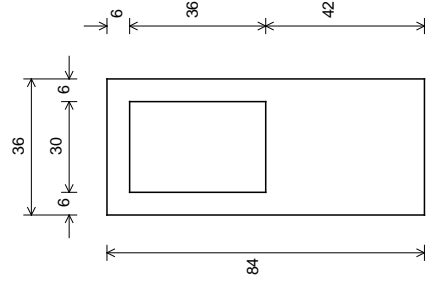

**Elev G**

**Muller Hardware and Supply Corp.**

9-665 Industrial Rd., Cambridge ON, N3H 5C9  
Tel 226-444-1060 Fax 610-271-5192

Project: Melburn ROI Inc. office addition  
Architect: ABC Design Inc.  
General Contractor: Sunshine Contracting.  
Date prepared: Nov 09,2010



**Shop drawing**

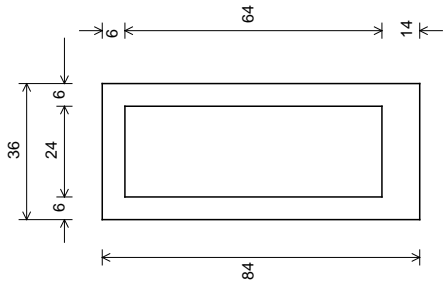

**Elev FG**

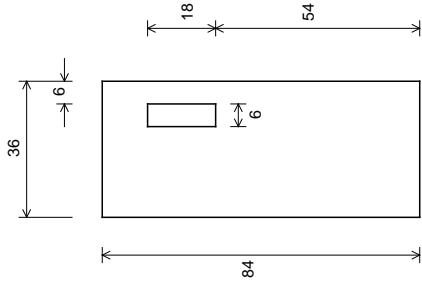

**Elev NL**

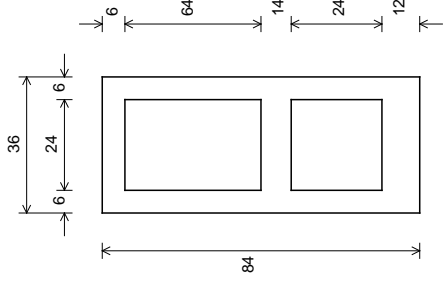

**Elev 2G**

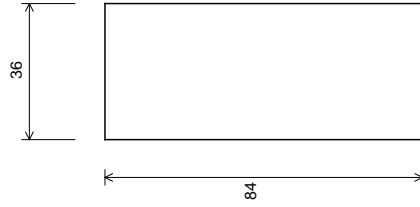

**Elev F**

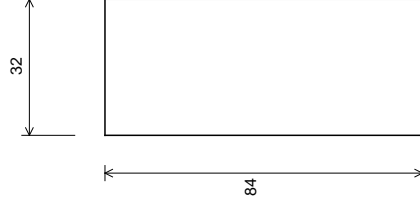

**Elev F**

**Muller Hardware and Supply Corp.**

9-665 Industrial Rd., Cambridge ON, N3H 5C9  
Tel 226-444-1060 Fax 610-271-5192

Project: Melburn ROI Inc. office addition  
Architect: ABC Design Inc.  
General Contractor: Sunshine Contracting.  
Date prepared: Nov 09,2010

**Shop drawing**





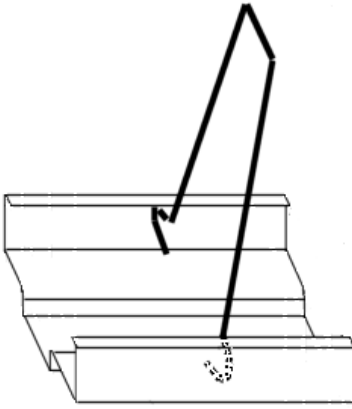

masonry (MA)

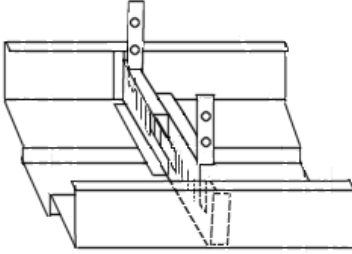

drywall (DW)

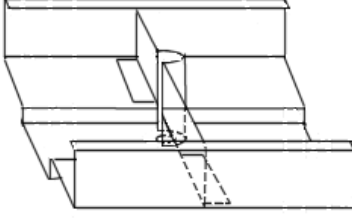

existing masonry anchor (EMA)

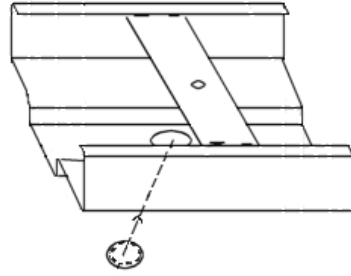

strap and plug (SP)

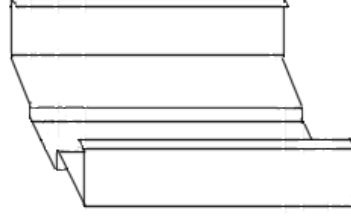
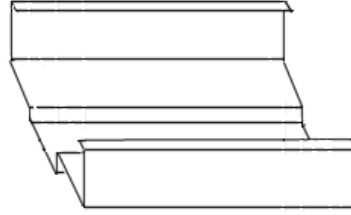

**Ancr Diagram**

**Muller Hardware and Supply Corp.**

9-665 Industrial Rd., Cambridge ON, N3H 5C9  
 Tel 226-444-1060 Fax 610-271-5192

Project: Melburn ROI Inc. office addition  
 Architect: ABC Design Inc.  
 General Contractor: Sunshine Contracting.  
 Date prepared: Nov 09,2010

**Shop drawing**



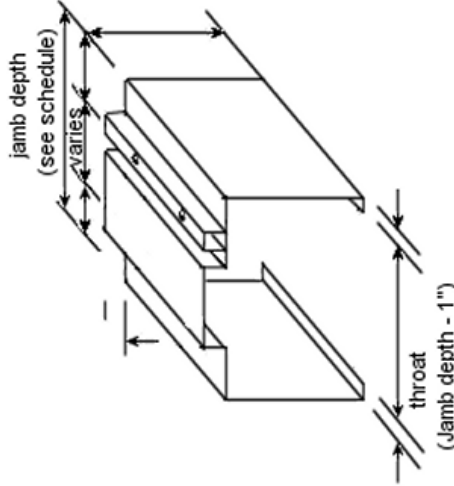
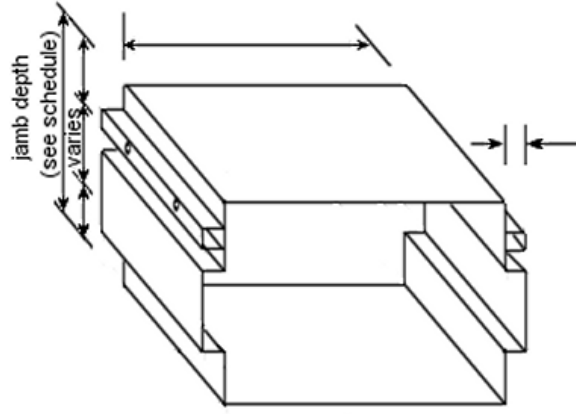
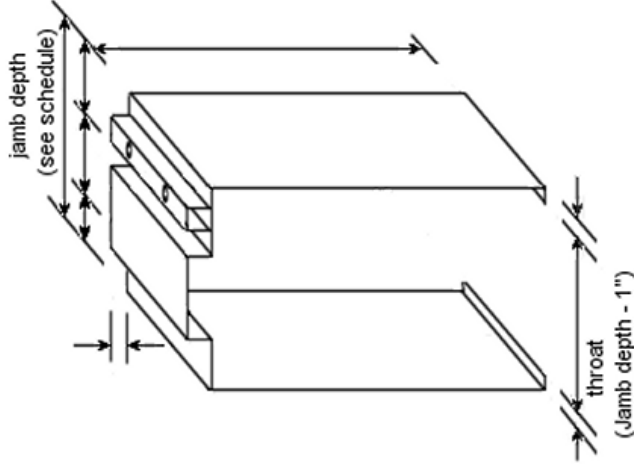
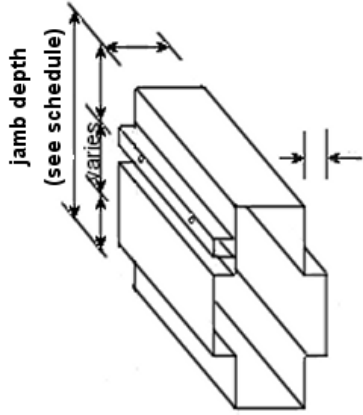
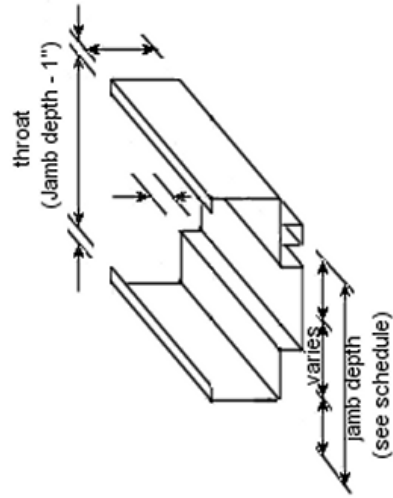

**Section Diagrams**

**Muller Hardware and Supply Corp.**

9-665 Industrial Rd., Cambridge ON, N3H 5C9  
 Tel 226-444-1060 Fax 610-271-5192

Project: Melburn ROI Inc. office addition  
 Architect: ABC Design Inc.  
 General Contractor: Sunshine Contracting.  
 Date prepared: Nov 09,2010

**Shop drawing**





# Hardware Schedule

Date: Nov 09,2010  
Customer: Sunshine Contracting.  
Project: Melburn ROI Inc. office addition  
Architect: ABC Design Inc.  
Our rep: Gerry Muller  
Our reference: Job #29  
Prepared by: DoorBoss admin 1

**Abbreviations**

Dr.= door  
Fr.= frame  
Anch.= anchor  
Ga.= guage  
Hcomb.= honeycomb core  
Poly= polystyrene core  
Wd.= wood (door)  
Hm.= hollow metal  
Ps. = pressed steel

**Finish codes**

605 Bright brass  
626 Dull chrome  
625 Bright chrome  
609 Dull brass, oxidized  
630 Dull stainless steel

**Heading # 1**

1 single door # 101 (101) - existing building to corridor 101 90-LHR  
 36 X 84 X 1 3/4 HM LS18 Door X HM Frame  
 .75hr Label

1	Continuous hinge	SL-11 83"	AL	SEL
1	Latchset	AL10S SAT 10-025	626	Sch
1	Closer	4140 H-Cush	689	Lcn
1	Floor Stop	CDH212	C26D	CDH
1	Kick Plate	CDH92A 8 x 34.5	C32D	CDH

**Note:** undersize door 3/16 for SL-11 continuous hinge

**Heading # 2**

1 single door # 102 (102) - corridor 101 to office 102 90-LH  
 1 single door # 103 (103) - Corridor 101 to office 103 90-RH  
 1 single door # 104 (104) - Corridor 101 to office 104 90-LH  
 1 single door # 105 (105) - Corridor 101 to office 105 90-RH  
 1 single door # 106 (106) - Corridor 101 to office 106 90-LH  
 1 single door # 107 (107) - Corridor 101 to office 107 90-RH  
 36 X 84 X 1 3/4 oak A25 Door X HM Frame

18	Hinge	BB1279 4.5 x 4	C26D	Hager
6	Lock Set	AL53PD SAT 10-025	626	Sch
6	Floor Stop	CDH212	C26D	CDH

**Heading # 3**

1 single door # 109 (109) - Corridor 108 to lunch room 108 90-LH  
 36 X 84 X 1 3/4 oak A25 Door X HM Frame

3	Hinge	BB1279 4.5 x 4	C26D	Hager
1	Latchset	AL10S SAT 10-025	626	Sch
1	Floor Stop	CDH212	C26D	CDH

**Heading # 4**

1 single door # 110 (110) - corridor 108 to mens restroom 110 90-LH  
 1 single door # 111 (111) - corridor 108 to womens restroom 111 90-RH  
 36 X 84 X 1 3/4 oak A25 Door X HM Frame

---

6	Hinge	BB1279 4.5 x 4	C26D	Hager
2	Pull	CDH5109-1	C32D	CDH
2	Push Plate	CDH93A 5 x 20	C32D	CDH
2	Closer	1460	689	Lcn
2	Floor Stop	CDH212	C26D	CDH
2	Kick Plate	CDH92A 8 x 34.5	C32D	CDH

**Heading # 5**

1 single door # 112 (112) - Corridor 108 to storage 112 90-LH  
 32 X 84 X 1 3/4 oak A25 Door X HM Frame  
 .75hr Label

---

3	Hinge	BB1279 4.5 x 4	C26D	Hager
1	Lock Set	AL80PD SAT 10=025	626	Sch
1	Floor Stop	CDH212	C26D	CDH

**Heading # 6**

1 pair doors # 113 (113) - Corridor 108 to boardroom 113 90-LHA/RH  
 36 X 84 X 1 3/4 oak A25 Door  
 36 X 84 X 1 3/4 oak A25 Door X HM Frame

---

6	Hinge	BB1279 4.5 x 4	C26D	Hager
2	Pull	CDH5109-1	C32D	CDH
2	Push Plate	CDH93A 5 x 20	C32D	CDH
2	Closer	1460	689	Lcn
2	Floor Stop	CDH212	C26D	CDH
2	Kick Plate	CDH92A 8 x 34.5	C32D	CDH

**Heading # 7**

1 single door # 114 (114) - Corridor 108 to exterior  
36 X 84 X 1 3/4 HM LS18 Door X HM Frame

---

90-RHR

3	Hinge	BB1168 4.5 x 4 NRP	630	Hager
1	Exit Device	22EO	689	Vd
1	Closer	4140 H-Cush	689	Lcn
1	Sweep	W13S/36	AL	PK
1	Threshold	CT10/36	AL	PK
1	Weatherstrip	W2/17	AL	PK

**Hardware summary**

1	- Continuous hinge * SL-11 83" * AL	SEL
1	- Weatherstrip * W2/17 * AL	PK
1	- Exit Device * 22EO * 689	Vd
1	- Threshold * CT10/36 * AL	PK
2	- Latchset * AL10S SAT 10-025 * 626	Sch
36	- Hinge * BB1279 4.5 x 4 * C26D	Hager
3	- Hinge * BB1168 4.5 x 4 NRP * 630	Hager
1	- Lock Set * AL80PD SAT 10=025 * 626	Sch
5	- Kick Plate * CDH92A 8 x 34.5 * C32D	CDH
2	- Closer * 4140 H-Cush * 689	Lcn
4	- Push Plate * CDH93A 5 x 20 * C32D	CDH
4	- Closer * 1460 * 689	Lcn
1	- Sweep * W13S/36 * AL	PK
4	- Pull * CDH5109-1 * C32D	CDH
6	- Lock Set * AL53PD SAT 10-025 * 626	Sch
13	- Floor Stop * CDH212 * C26D	CDH





# Muller Hardware and Supply Corp.

9-665 Industrial Rd., Cambridge ON, N3H 5C9 Tel 226-444-1060 Fax 610-271-5192

## Shipping bill #29-1

Date: Nov 09,2010  
Customer: Sunshine Contracting.  
Project: Melburn ROI Inc. office addition  
Site address: 222 22 St. W, Melbourn Fl.  
Contact: Jack Nicholson  
Phone: 222-222-2456  
Prepared by: Gerry Muller

### Hardware (PO: 2591)

- 3 1580 - Hinge \* BB1168 4.5 x 4 NRP \* 630
- 1 2000 - Closer \* 4140 H-Cush \* 689
- 1 2002 - Exit Device \* 22EO \* 689

### Doors (PO: 2589 2590)

- 1 Custom - 36 \* 84 \* 1 3/4 \* HM \* PolyS \* 161 \* NL \* LS18 \* RHR \* (Opening: 114)

### Frames, screens, borrowed lights (PO: 2589 2590)

- 1 Custom - 40 \* 86 \* 5 3/4 \* HM \* A AS16 \* LHR \* .75hr \* Strap anchor LHR Frame (Opening: 101)
- 1 Custom - 60 \* 86 \* 5 3/4 \* HM \* C (L) AS16 \* LH \* \* Drywall Clips LH Frame (Opening: 102)
- 1 Custom - 60 \* 86 \* 5 3/4 \* HM \* C (L) AS16 \* RH \* \* Drywall Clips RH Frame (Opening: 103)
- 1 Custom - 60 \* 86 \* 5 3/4 \* HM \* C (L) AS16 \* LH \* \* Drywall Clips LH Frame (Opening: 104)
- 1 Custom - 60 \* 86 \* 5 3/4 \* HM \* C (L) AS16 \* LH \* \* Drywall Clips LH Frame (Opening: 106)
- 1 Custom - 60 \* 86 \* 5 3/4 \* HM \* C (L) AS16 \* RH \* \* Drywall Clips RH Frame (Opening: 105)
- 1 Custom - 60 \* 86 \* 5 3/4 \* HM \* C (L) AS16 \* RH \* \* Drywall Clips RH Frame (Opening: 107)
- 1 Custom - 40 \* 86 \* 5 5/8 \* HM \* A DW18 \* LH \* \* LH Frame (Opening: 109)
- 1 Custom - 40 \* 86 \* 5 5/8 \* HM \* A DW18 \* LH \* \* LH Frame (Opening: 110)
- 1 Custom - 40 \* 86 \* 5 5/8 \* HM \* A DW18 \* RH \* \* RH Frame (Opening: 111)
- 1 Custom - 36 \* 86 \* 5 5/8 \* HM \* A DW18 \* LH \* .75hr \* LH Frame (Opening: 112)
- 1 Custom - 96 \* 86 \* 5 3/4 \* HM \* D (R) DBL AS16 \* LHA/RH \* \* Drywall Clips LHA/RH Frame (Opening: 113)
- 1 Custom - 40 \* 110 \* 8 3/4 \* HM \* TRA AS16 \* RHR \* \* Wire Masonry RHR Frame (Opening: 114)

### Miscellaneous

Must be on jobsite prior to 12:00.

Received by: \_\_\_\_\_ Date: \_\_\_\_\_

All goods deemed received in proper order.



# Muller Hardware and Supply Corp.

9-665 Industrial Rd., Cambridge ON, N3H 5C9 Tel 226-444-1060 Fax 610-271-5192

## Sunshine Contracting.

555 22 St.  
Orlando, FL 458742

**Date:** Nov 09,2010

**Invoice #:**

**Job/Issue:** 29-1

**Customer PO:** 2591

**Project:** Melburn ROI Inc. office addition

Qty	Type	Op#	Description	Price
3	Hardware		1580 - Hinge * BB1168 4.5 x 4 NRP * 630	\$ 112.50
1	Hardware		2000 - Closer * 4140 H-Cush * 689	\$ 225.00
1	Hardware		2002 - Exit Device * 22EO * 689	\$ 225.00
Sub total:				\$ 562.50
County tax(4.00%):				\$ 22.50
<b>Grand total:</b>				<b>\$ 585.00</b>

## Terms and conditions

Full amount due withing 30 days.

2% discount for payment within 5 days from invoice date.

## Notes

This invoice fits into a standard window envelope.

You also have the option of printing line item pricing when required.



# Muller Hardware and Supply Corp.

9-665 Industrial Rd., Cambridge ON, N3H 5C9 Tel 226-444-1060 Fax 610-271-5192

**Invoice #:****Job/Issue:** 29-1**Customer PO:** 2589**Project:** Melburn ROI Inc. office addition

Qty	Type	Op#	Description	Price	
1	Door	114	Custom - 36 * 84 * 1 3/4 * HM * PolyS * 161 * NL * LS18 * RHR *	\$ 303.00	
1	Frame	101	40 * 86 * 5 3/4 * HM * A AS16 * LHR * .75hr * Strap anchor	\$ 102.00	
1	Screen	102	60 * 86 * 5 3/4 * HM * C (L) AS16 * LH * * Drywall Clips	\$ 217.50	
1	Screen	103	60 * 86 * 5 3/4 * HM * C (L) AS16 * RH * * Drywall Clips	\$ 262.50	
1	Screen	104	60 * 86 * 5 3/4 * HM * C (L) AS16 * LH * * Drywall Clips	\$ 262.50	
1	Screen	106	60 * 86 * 5 3/4 * HM * C (L) AS16 * LH * * Drywall Clips	\$ 262.50	
1	Screen	105	60 * 86 * 5 3/4 * HM * C (L) AS16 * RH * * Drywall Clips	\$ 262.50	
1	Screen	107	60 * 86 * 5 3/4 * HM * C (L) AS16 * RH * * Drywall Clips	\$ 262.50	
1	Frame	109	40 * 86 * 5 5/8 * HM * A DW18 * LH * *	\$ 60.30	
1	Frame	110	40 * 86 * 5 5/8 * HM * A DW18 * LH * *	\$ 60.30	
1	Frame	111	40 * 86 * 5 5/8 * HM * A DW18 * RH * *	\$ 60.30	
1	Frame	112	36 * 86 * 5 5/8 * HM * A DW18 * LH * .75hr *	\$ 70.43	
1	Screen	113	96 * 86 * 5 3/4 * HM * D (R) DBL AS16 * LHA/RH * * Drywall Clips	\$ 531.00	
1	Frame	114	40 * 110 * 8 3/4 * HM * TRA AS16 * RHR * * Wire Masonry	\$ 187.50	
				Sub total:	\$ 2,904.83
				County tax(4.00%):	\$ 116.19
				<b>Grand total:</b>	<b>\$ 3,021.02</b>

## Terms and conditions

Full amount due withing 30 days.

2% discount for payment within 5 days from invoice date.

## Notes

This invoice fits into a standard window envelope.

You also have the option of printing line item pricing when required.